

SWAFFHAM RACEWAY



OVAL RACING FOR ALL AGES

SWAFFHAM ROOKIE RODS 2020

Rules & Regulations

1. THE FORMULA

This formula is designed to encourage new drivers to our circuits, to enjoy the atmosphere & thrills of driving on an oval, without the substantial financial investment. It also gives the opportunity to race to those drivers who cannot give the commitment necessary to compete at the very high level of all our other Formulas.

The object of the racing in the Rookie Rod formula is to complete the specified number of laps in the shortest time without contact with the other cars on the track. As it is a strictly Non-contact form of racing any pushing, nudging, spinning or baulking of the other cars will incur penalties from the Steward of the meeting. Points will be awarded to the finishing places and when accumulated these points will be the basis for a driver grading system. Those new to the racing or low point scorers will start at the front of the grid and will be required to have a White fin plate. Drivers scoring points will move up the grading system to a Yellow coloured fin plate followed by Blue & then a Red fin plate. As you move up the grades your starting position on the grid will move back along the track, similar to a handicapping system.

The Clerk of the course can at any time move you to another grade if he thinks it appropriate to do so.

Racing is in a clockwise direction on a clearly defined circuit with a separate infield. Any wheels passing over the demarcation lines or entering on to the grassed infield areas will mean that the driver will be penalised.

2. WHO CAN RACE

- All Rookie Rod Drivers must apply for a Swaffham licence which costs £40.00 for the year.
- Once registered it then entitles you to pick your race number, subject to availability, and you will be issued with a copy of the Rookie Rod Rules & Specifications.
- You may only race if you are pre-booked through the page. This will be on a first come first served basis, so book early.
- At a meeting all Drivers must book in at the Pit office with their Log Book, where they will be given an entry ticket for themselves and one complimentary ticket.
- You must be over 16 years of age to Race a Rookie Rod.
- You can race a Rookie Rod if you have been registered or are currently registered as a Banger driver.
- You may race a Rookie Rod if you previously held a Ministox licence.

3. WHAT TO DO NEXT

- Check through the fixture list for the Rookie Rod fixtures and select a meeting or meetings.
- Book in via the page
- On arrival at the Stadium you must first book in at the pit office and pay any fees applicable.
- You must then get the car Scrutineered and obtain the Passed Scrutineering Sticker which has to be displayed in a prominent position on the car.
- Ensure you are familiar with the raceway flags and the rules of racing, as you are now ready to race and will come under all the Rules & Regulations, similar to all the other formula.

4. ELIGIBLE CARS.

All cars must run with a carburettor as no fuel injected cars are permitted to race.

- Vauxhall Nova 1200 cc, but no SRi parts are allowed. **The Vauxhall Corsa A, B and C models are permitted with full Nova engine specifications.**
- Ford Fiesta up to 1300cc, Mk 1 – 3.

The Ford OHV HSE engine before 1992 is permitted, but the ignition module will need to be checked & sealed.



5. INITIAL PREPARATIONS.

- Remove all exterior mouldings, screen glass, lamps and handles.
- Remove all interior trim, the dash & passenger seating.
- Remove the fuel tank, spare wheel carrier & tow bar if fitted.
- Remove all obsolete wiring and interior debris from the car.
- The plastic front & rear bumpers must be retained & refitted when the car is raced.
- Read & familiarise yourself with the ROOKIE ROD Rules & Regulations for preparing the race car.

6. PERSONAL SAFETY

- Drivers are advised that under Health & Safety, they are responsible for their own and their Mechanic's actions. Promoters have had complaints made about Registered Drivers & also Mechanics, consuming large amounts of alcohol at meetings, which could effect their judgement or be detrimental to their health, when medical attention has to be administered by Paramedics, St Johns or Hospital Staff.
- Should an incident occur that proves fatal on the raceway and you are involved, it is likely that the Police will want interview you. **If you drive, don't drink!** Scrutineers and Officials will report to the Clerk of the Course, anybody they believe is under the influence of Drink or Drugs.
- Drivers whom it is thought are under the influence, may be breathalysed. You have been warned!

Flags as used by the Starting Marshall & Trackside Safety Staff.

- Waved Green Flag – Go, the race is on.
- Waved Red Flag – Stop racing, slow down & stop immediately.
- Chequered Flag – Race winner has crossed the line, continue to race until the Red Flag is shown.
- Held Yellow Flag – Beware, you are approaching a hazard on the track, continue to race.
- Waved Yellow – Slow down to 15mph, hold your position, **and do not** overtake any other cars.
- White Flag with a Blue spot – Oil on the track.
- A Blue Flag – This is shown to a driver who must hold his racing line. You may be holding up another driver who has been trying to pass you but is being baulked, or you are spoiling a race by holding up a pack behind you, by your driving style. Once shown the flag you must either hold a racing line on the inner part of the track or the outer part of the track, not weave between both. If after two laps you fail to obey this Blue Flag you will shown a Blue & White Flag.
- Blue & White Flag – Give up your track position, you have not taken notice of the Blue flags.
- Black cross on a White board – You have committed an infringement and may be penalised in the results.
- Waved Black Flag - You are disqualified, pull off the track immediately.
- White Flag with Red Cross – Technical Disqualification, leave track immediately
(Drivers are also reminded that they should line up on the grid with their engines switched off in the correct points order, unless told otherwise.)

7. SAFETY EQUIPMENT.

- **CRASH HELMET** - Helmets must be of a minimum standard as directed by British Oval Racing Safety Executive (B.O.R.S.E). These are FIA8860-2004, FIA8860-2010, Snell SA2005, Snell SA2010, Snell SA2015, SFI Foundation 31.1A, SFI Foundation 31.2A. The E2205 European standard helmet may be used in Fibreglass, Carbon or Tri-Composite form only i.e. NO POLYCARBONATE helmets are allowed. It is important that the helmet fits the driver correctly. Shatterproof goggles/visors must be worn although tinted visors are not advisable. Your helmet must display the current ORCi (ORC15) sticker.
- **RACING OVERALLS** - You must wear Fire retardant, clean, un-torn and brightly coloured Racing Overalls, that are made of a fire retardant material and are clearly marked fireproof. Mechanics are also required to wear clean overalls and will not be permitted on to the track without them being on, when instructed to do so.
- **GLOVES** - It is Mandatory to wear Fire retardant Gloves also clearly marked fireproof.
- **BALACLAVAS** - It is Mandatory to wear Fire retardant Balaclavas clearly marked fireproof.
- **A NECK BRACE** - is Mandatory to wear a neck brace, so to is a spine support.
- **WET WEATHER CLOTHING** - is also recommended and must be worn in addition to, and **not** instead of the racing overalls.

8. 2kg FIRE EXTINGUISHER

All tow vehicles, must carry a minimum of a 2kg fire extinguisher dry powder or gas, which must be within easy reach of the driver and mechanics at all times, especially when refuelling.

9. DRIVERS SEAT WITH HEAD RESTRAINT/WINDOW NETS - You must have a Driving Seat with a head restraint and this may be of a competition type. The seat should occupy its original position where possible and be suitably supported at shoulder height and on both of the sides and back, with a suitable framework or seat stiffener's.

Additional wrap around seat support at shoulder height.

You may fit a Head Restraint Net on the on the safety fence side of the race car only. A quick release window net must be fitted to the driver's door window aperture and must be of quick release/cloth type only. Net spacing must be 76mm x 76mm maximum.

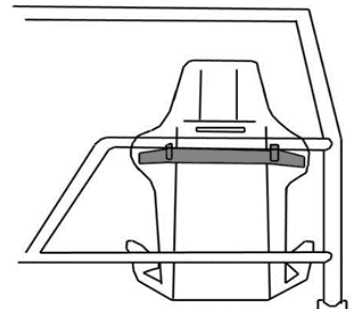

10. SAFETY HARNESS

- The lap belt/straps and crotch straps should not pass over the sides of the seat, but through it, in order to wrap and hold the pelvic region over the greatest possible surface. It is mandatory to have a 5 point Safety harness with 3" shoulder straps, the lap & crotch straps can be either 2" or 3" in width. All seatbelt connection points must be visible and no belts pass through any firewall.
- Following research made by leading safety harness manufacturers, information has been made available with regard to the best way to fit your safety harness; this will further ensure your safety.
- The lap belt crossing should be below the anterior-superior iliac spines (bony part of the hip). Under no circumstances should it be worn over the region of the abdomen.
- Lap belt/straps must terminate vertically downwards, and not forwards or rearwards of the hip joint. Lap straps should terminate symmetrically about the wearer on either side of the seat, about 20" (500mm) apart. The distance between the seating surface and the anchorage point should be kept to a minimum to prevent submarining. The location of the crotch strap mounting should be to the rear of the driver.
- Fig.1 shows the location for the tail straps, which should be horizontal to 20° below horizontal, and as close to the shoulder as is practical for optimum restraint.
- Only safety belts comprising of separate shoulder, lap, and sub-straps will be permitted.
- The sub-strap must be used at all times, and all belts must connect to the quick release buckle. The abdominal strap fixing point must be on the chassis, roll cage, or floor (for vehicles with no chassis), either side of the driver.
- The shoulder straps must be supported at shoulder height. NASCAR type buckles must be fitted with lever on the right side of the driver. It is advisable to fit a secondary means of detent to prevent overall sleeves accidentally unhooking the buckle during racing. A small section of tube grip elasticated bandage, slid over the hooked buckle, serves the purpose.
- Special attention must be paid to the condition of seat belt fixings once fitted. Information is available, from your Promotion, on the correct procedure to follow when fitting seat belts. *Remember - your life depends on them, and belts, once involved in a severe accident, should be discarded and replaced.*
- Over the years, we have had many unnecessary injuries due to badly fitted seats. They frequently occur in Non-contact Formulas, when perhaps a driver believes it is more unlikely that he will be involved in a serious crash, and he also believes that, if he is involved in a collision, the impact on his car will be from the front. However, this is often not the case. It is therefore, imperative that you ensure your seat is really well supported, especially where the shoulder straps go through. You must also ensure that your seat cannot move sideways.

The safety of your seat will be judged by the Scrutineer's and you will only be permitted to race when they are satisfied that you will be as safe as possible in any event.

11. RACE CAR SPECIFICATIONS

VIOLATIONS

- When referring to the engine, gearbox, final drive, mechanical or construction Rules & Regulations, the principle will always be: *Unless permission is specifically granted to make modifications, (or any variation) nothing may be done to alter or change the Standard Parts in any way.*
- It is the responsibility of the Driver to prove to the Promotion that the part is legal, by way of written proof of where the part originated. This must be undertaken within 7 days, otherwise the item in question will be deemed illegal, resulting in immediate suspension from racing & referral for disciplinary action. **Unless the rules say you can do it, you cannot do it!**
- Presentation of a Vehicle for Scrutineering is a declaration by the entrant that the vehicle is eligible for that event.
- Car engines & fuel will be checked on a random basis. Violations or refusal to allow an engine check will result in an immediate suspension of all racing facilities.
- All Car and Engine Specifications will be taken from either the manufacturers Technical Specifications or the Technical Service Data books as published by Glass's Guide.
- Should a discrepancy occur between the Specifications then the Promotion will exercise its judgement, and that decision will be final.
- Clarification on any one item may be sought from the Promoter.
- Each driver is permitted one car per meeting & each car is permitted one driver per meeting.

12. VEHICLE WEIGHT.

Cars may be checked at any time for being under weight or having too much weight on the right-hand side of the car.

- The minimum car weights are as follows: Nova/Corsa **700kg** Fiesta 690 kg
- To achieve this new weight more tubing must be added to the roll cage not just ballast.
- *There is a maximum ballast weight of 20kg only*
- Ballast must be steel plate bolted to the floor. This internal plating must be of equal proportions in the front and rear in construction and gauge e.g. if 5kg is fitted in the front nearside footwell, 5kg must be fitted in the back nearside footwell. Bolts of equal size and material must be used to fit the plates, the plates must be either bolted or welded. More weight may be added on the nearside than the offside
- The maximum permissible weight on the drivers or right-hand side is 52% of the total vehicle weight. If you break this rule points/monies and penalties will be imposed upon you.
- If you are checked and over the 52% but under 52.5% on your first offence you will lose all points/monies due on the day and receive a final warning & loaded for the day. You must have this written in your log book.
- If you are found on a second occasion to be over 52% but under 52.5% you will receive a one meeting suspension from your registered promotion
- Anyone over 52.5% on their first check will receive an automatic one meeting ban and loaded immediately with loss of any points or monies due (if applicable).
- If a driver is found over 52.5% on a second occasion the penalty will automatically be doubled, or possibly carry a longer suspension. Checks will be carried out at any time.

| Underweight Vehicle Bans | |
|--------------------------|-------------------------|
| Car Underweight by: | Banned From Racing For: |
| 0.001kg – 1.0kg | 1 month |
| 1.001kg – 2.0kg | 2 months |
| 2.001kg – 3.0kg | 3 months |
| 3.001kg & over | 6 months |

13. WHEELBASE

Mk2 Fiesta wheelbase is 2288mm or 90.1"

Mk3 Fiesta wheelbase is 2446mm or 96.3"

Nova wheelbase is 2343mm or 92.2"

Corsa wheelbase is 2443mm or 96.2"

Corsa C wheelbase is 2491mm or 98.07"

- The wheelbase on both side of the car must be standard + or -- 25.4mm or 1" (This means rather ½" or 12.7mm on both wheels or one wheel standard wheel base and the other one to a maximum of 1" or 25.4mm forward or backwards). When the wheel base is checked the driver will be asked to set their wheels where they want them & once one side is measured they are not allowed to move the wheels to measure the other side.
- When repairs have been made to the suspension using standard parts & the wheelbase is found to be incorrect, washers may be added or removed from the front tie-bars or anti-roll bars only to bring it within specifications.

14. ROLL CAGE. *(Aluminium Roll Cages are NOT permitted).*

Key: SHS - Square Hollow Section.

RHS – Rectangular Hollow Section.

CHS – Circular Hollow Section.

The roll cage must be constructed from a minimum of 32mm(3mm) or a maximum of 38mm(2.5mm)

CHS steel tube. RAC approved cages are permitted but must have a minimum wall thickness of 2.5mm. All welds must be a minimum of 90%. The Cage must fit tight to the body shell with no gaps and support both the A & B pillars.

The cage must consist of the following minimum iron work:

- One front hoop over the A posts.
- One rear hoop over the B posts.
- Three rail roof bars connecting the A & B hoops.
- There must be one front crossbar going across the bottom of the window aperture to a maximum of 5inches down. There must be one crossbar behind the driver, which must be at shoulder height to support the seat.
- It is recommended that an additional rear B post bar is welded in at floor level.
- The roll cage hoop feet must be welded to four 3mm thick plates 100mm square or to a piece of bar or box 38x38mm with a minimum thickness of 2.5mm, connecting the front & rear hoop feet & welded to the floor. This bar does not replace a door chicken bar.
- Two door chicken bars with connecting bracing fitted to both doors, the lower bar being 75mm or 3" above the door sill.
- Rear facing ironwork from off of the cage is permitted but it must terminate 100mm or 4" from the back panel.
- Both suspension turrets can be supported by two brace bars from off of the front of the cage going through the bulkhead, but it must be made from the same material as the cage.
- Any part of the cage coming in to contact with the driver must be padded.
- You must have a minimum two stay bars (must be either Fig 2 (b) or 2 (c)) coming from the hoop B down towards the rear panel but must finish at least 4" in front of the rear panel.

You must fit two vehicle lifting eyes under the bonnet & a further two at the rear, in the area of the boot, for vehicle recovery purpose. However, if you have a chassis or roll-cage member that will do the same function, then the eyes do not have to be fitted.

If Structural stiffeners have been removed then sill bars must be fitted made from roll cage material & connected to the A&B pillar of the roll cage & must include a minimum of 2 connecting bars each side.

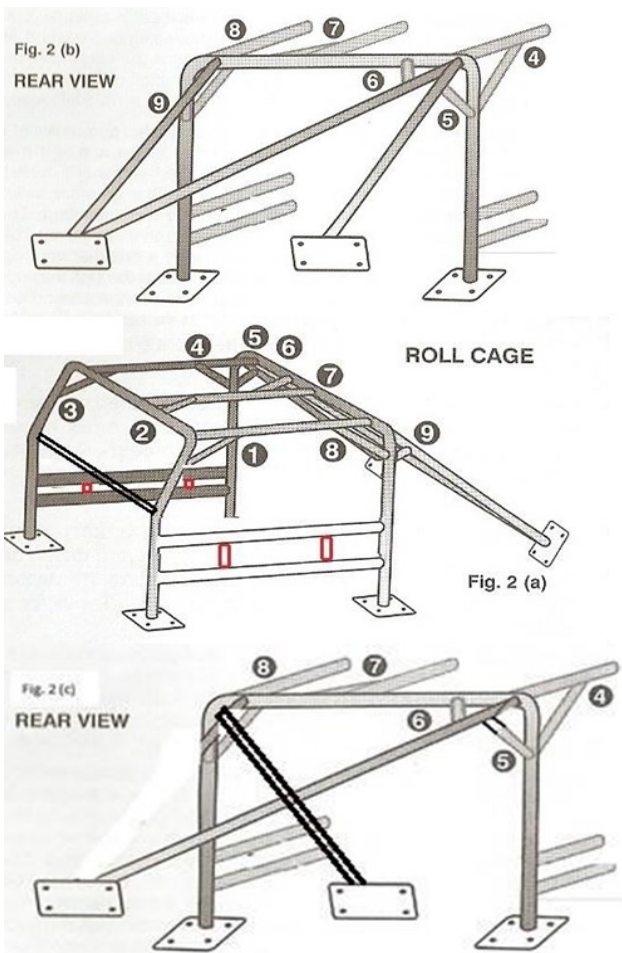

Corner gusset bars are included in the diagrams to be added as a means to add weight to the car if necessary.

15. BODYSHELL.

To remain as standard but with the following exceptions:

- The Bonnet and Tailgate may have the strengthening bracing removed (Skinning).
- The Doors & Rear Wings below the cars waist-line, may have the inner panels removed except on a Corsa C which you can remove the roof lining & rear pillars but not the A&B pillars.
- The Headlamp apertures may be filled in with metal of the same thickness as that of the body panels.
- The Original plastic front and rear bumpers must be fitted to the car.
- The Front Grill must be fitted at all times when racing.
- Passenger Door must be either welded or bolted shut.
- Drivers Door may open but then it must have secondary means of fixing, like an over clip.
- Tail gate may be either welded or bolted in position.
- A metal upright, to a maximum 38mm, minimum 19mm, box or tube, must be welded or bolted to the centre of the window aperture. No wire mesh must grille must be used in front of the driver
- No aerofoils or spoilers are permitted apart from those fitted by the manufacturer.
- Bonnet may be removable, but it must be securely fixed front & back with some form of locking pins. (Two triangular gussets, 100x100mm or 4x4", may be welded at the bottom of the windscreen aperture to secure the bonnet corners).
- Support for corners of the wings to a maximum 12mm tube by 2mm wall thickness and supported by 2inch square plates with a maximum thickness of 2mm.
- Below is a bracket which you may put on a Corsa C from the chassis out to the front bumper to support the end of the bumper. This is the maximum size allowed and must be bolted and not welded in place with a maximum of 2 bolts each end.

50mm max

16. THE SUSPENSION.

- Fiesta: if an anti-roll bar was an original fitment, then it can remain, otherwise No anti-roll bars are permitted front or rear.

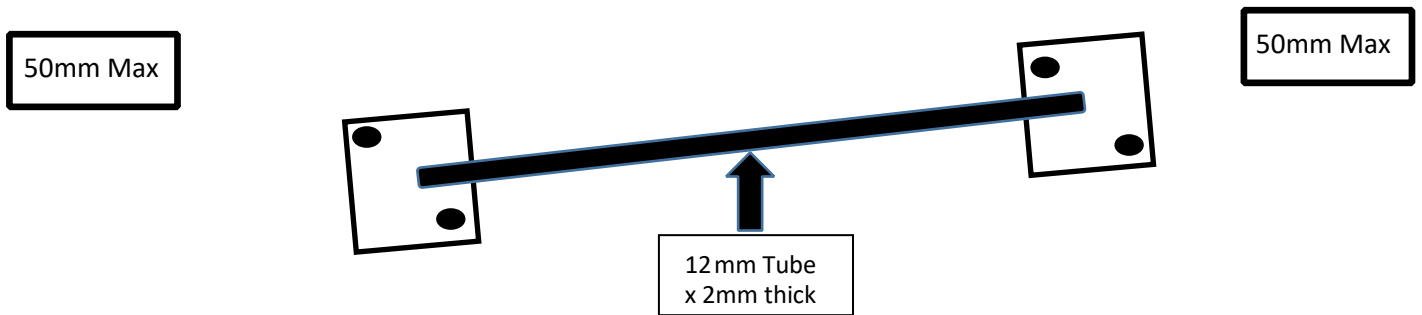

(Nova: may use an anti-roll bar on the FRONT only, but it must be from the manufacturers range.)

- Negative Camber is only permitted on the Nearside front wheel, **up to 37.5mm or 1¹/₂ in the tyre, from top to bottom.** This is achieved by extending the lower suspension arm or re-positioning the outer swivel joint a maximum of 25mm or 1". This must be a permanent fixing not and adjustable type. No other way to achieve negative camber is permitted I E wrong bolts, bent leg, bent hub.
- Both the front tie-rods can be shortened or lengthened to suit, but again they must not be adjustable. You may use slot washers in there to give you the correct wheelbase
- All suspension parts must be located on the original mounting points on the chassis & body.
- Only standard bushes are permitted.

17. STEERING.

- The Steering Rack should be standard, but the adjusting rod may be lengthened on the NEAR SIDE ONLY.
- The steering column height & length may be adjusted to suit the driver.
- The upper column support bracket may be reinforced.
- A quick release steering wheel is permitted.

18. FRONT SPRINGS.

You are not permitted to use the original manufacturers springs. You must use two SUPLEX springs obtainable from your local factor, Part No. 10029, with a free length of 279mm. or alternatively a BOGE 252770, or from Partco a PSCF100. or a KYB-KRA5041 (this part has now been superseded by the KYB-KRA5290 – either are permitted for use.)

NB. Suplex springs come in two versions with the same part number, one has a thinner wire diameter at one end, either may be used.

FIESTA FITMENT.

The Fence side or NSF spring; this may be shortened from its original length of 279mm to 229mm only, no shorter. As the spring is not an original the top & bottom coils may be heated and formed to fit into the original locating positions on the damper assembly.

The Inside or OSF spring; this may be cut to any length to allow for the suspension set up. Again the ends of the coils may be heated & formed to fit into the original locations on the damper assembly.

NOVA/CORSA FITMENT.

The Fence side or NSF spring; this may be shortened from its original length of 279mm to 190mm only, no shorter. As the spring is not an original the top & bottom coils may be heated and formed to fit into the original locating positions on the damper assembly. However, a top spring cup from a Fiesta can be used or a similar cup used, to locate the top of the spring.

The Inside or OSF spring; this may be cut to any length to allow for suspension set up. Again the ends of the coils may be heated & formed to fit into the original locations on the damper assembly.

19. REAR SPRINGS

- These must be the originals to the car being used but they may be shortened by removing coils or cutting & welding.

20. SHOCK ABSORBERS

- The shock absorber cannot be modified in anyway.
- No GAS or competition shock absorbers are permitted except on the Corsa C where you can use a Gas shocker but only the part numbers below.
- Shock absorbers must be as original or direct replacements.
- Shock absorbers must be as from manufacturer, i.e.: KYB shocker must remain with KYB components incl oil, No interchanging of parts or oil.

These part numbers may be used for cross-reference.

| | |
|------------------|---|
| Fiesta Mk2 Front | Monroe 11061 or Boge 27 / 617 / 0 |
| Fiesta Mk2 Rear | Monroe 11077 or Boge 32 / 495 / |
| Fiesta Mk3 Front | Monroe 11117 or Boge 27 / A28 / 0 |
| Fiesta Mk3 Front | 633818 |
| Fiesta Mk3 Rear | Monroe R3756 or Boge 27 / A29 / 0 |
| Fiesta Mk3 Rear | Kayaba 441801 |
| Nova Front | Monroe G16203 or Boge 27 / 683 / 0 |
| Nova Front | Kayaba 633831 or Kayaba 333831 |
| Nova Rear | Monroe R23456 or Boge 27 / 401 / 0 |
| Nova Rear | Kayaba 443225 |
| Corsa Front | Kayaba 633831 / 333831 - Monroe G16203 or Boge 27 / 683 / 0 |
| Corsa Rear | Kayaba 443225 - Monroe R23456 or Boge 27 / 401 / 0 |
| Corsa C Front | KYB 333755 (Drivers side) or Boge 30B78A |
| Corsa C Front | KYB 333756 (Passenger side) or Boge 30B79A |
| Corsa C Back | KYB 343350 or Boge 27F35A |

21. WHEEL RIMS.

- Only the standard manufacturer' 5 1/2 J Maximum steel wheel rims are permitted dished in & dished out. NO alloy or Rostyle wheels.
- All wheel nuts must be fitted.
- No wheel weights or hub caps are allowed.

22. TYRES

- The only tyre permitted for use will be a Pace PC50 175/70/13.
- Tyre buffing is permitted.
- Tyre softener or any tyre contamination is not permitted

23. BRAKES

- These must be as standard to the model, be working on all four wheels & without any modifications.
- The handbrake must be operational on the rear wheels.
- You may remove or change rear brake pressure valve but no adjustable type.

24. GEARBOX & FINAL DRIVE

- The gearbox must be the standard one as produced by the manufacturer, but you may change the gear ratios by using transmissions from within the model range. Note, you cannot modify a transmission or a component to make it fit.
- No locked or limited slip differentials are allowed.
- Drive shafts may be interchanged when gearboxes are being changed.
- On occasions when the driveshaft keeps popping the C.V. joint, you may lengthen the shaft to prevent this from occurring.
- 2.2.1 and 2.1.8 Gear Clusters are not permitted for use in this formula.

25. ENGINE

- The Engine must remain in its standard form as specific to the model without special Cams, Springs, Lightening / Balancing of parts or changing any engine components.
- Exceptions to the above are that the head may be surfaced: The Nova head minimum thickness is 94.55mm, Fiesta 1300 CVH can have a minimum combustion chamber depth of 18.60mm. Fiesta OHV is not applicable as it is a flat head anyway. The Fiesta Mk3 can have the 1300 CVH engine fitted to it.
- The cylinder block cannot be surfaced.
- Maximum cylinder overbore is 1mm.
- The oil pick-up pipe may be re-positioned to avoid engine damage.
- Engine mountings to remain standard although the top mount next to the valve cover may be solid.
- As from the 1st January 2016 all drivers must use the new Kent cam provided. Please speak to your rep about purchase of these
- You may fit a gasket between the cam box and the cylinder head.
- Valve stems must not be machined but you may use a pattern part valve which will measure a minimum length of 104.6mm.

26. OIL CATCH TANK.

- A 0.5 litre oil catch tank (no drink cans or bottles) must be fitted in the engine bay.
- The tank must have a minimum of 2 breather pipes connected to it: one from the rocker box & one from the crankcase.
- Ineffective tanks during racing or practice will mean the car being withdrawn from the event.
- Nova's may use the Corsa Rocker Cover.

27. IGNITION SYSTEM - DISTRIBUTOR.

- The ignition system must be as standard, & using the correct distributor and ignition coil for the engine.
- The vacuum unit must be fitted, But it may or may not be working. Vacuum hose maybe removed & Carburettor end maybe blanked off.
- The mechanical advance may not be altered or locked in any way and must be moving at all times.
- The distributor base plate must be attached to the vacuum unit. It must not be secured & must be movable.

28. CARBURETTOR & INLET MANIFOLD

- The carburettor body must not be altered or modified in any way.
- The standard inlet manifold must be used. Nova/Corsa can use the 1300 standard inlet manifold to fit the pierburg 2E3 carburettor.
- The cold starting Choke Butterflies may be removed.
- Economy devices must remain and be as manufactured.
- Throttle butterflies may not be modified to open together in any way. You are allowed to change any air or fuel jets.
- The Nova must use the Pierburg 2E3 with Venturi's of 20 /24mm and a 8mm/7mm preatomiser diameter. Needle valve/fuel inlet must be no larger than 1.55mm as standard. This will be checked by using a 1.6mm drill bit which must not enter the hole.
- The Fiesta Mk1 OHV may use the Mk1 1300cc sport carburettor
- The Fiesta using the HSE engine must use the original twin choke 1300 carburettor.
- The Fiesta using the 1300 CVH engine must use the Ford 1300cc VV carburettor. The identity numbers are 81SF9510KCA, 84SF9510KEA, 84SF9510KWA, although I have found that there are others numbers for a 1300 carburettor. Please see your Scrutineer.
- A secondary fixing is required on the Carburettor fuel inlet pipe.

29.FUEL SYSTEM.

- Fuel tanks must be metal or FIA approved & fitted behind the driver but in front of the rear axle centre line.
- The tank must have a maximum capacity of 9 litres.
- The fuel tank must be above the floor or rear seat and must not be cut in any way to fit. Four 50mm diameter holes should be drilled for drainage purposes.
- Fuel caps must be of a metal screw type, no push fit types are allowed
- The fuel outlet must be from the top of the tank.
- The tank must have a positive means of fixing.
- A breather pipe must be fitted which should incorporate a one – way valve, with the pipe terminating below the tank so as to prevent spillage if inverted.
- All fuel lines must be inside the car and be metal or metal covered.
- A fuel shut off tap must be within easy reach of the driver.
- A complete fire wall must cover the tank.
- You cannot enclose the rear boot area from the seat to the rear window aperture.
- Fuel pumps must be original, no electric pumps are permitted.
- Only roadside fuel can be used. No additives are allowed.

All Oval Racing Formula

Permitted fuel specification from 1st January 2008 (this specification supersedes all previous specs).

- All cars must only use fuel from roadside pumps as defined below.
- Petrol (Motor Gasoline of the type on sale to the general public from roadside filling stations) BS 4040 (Leaded) Subject to a valid permit for use. LRG (Unleaded), BS EN 228 (Unleaded), BS7800 (Super Unleaded).
- Petrol is a product refined from crude oil that contains a large number of identifiable compounds that can typically be 250 in number. These compounds can be identified and compared to the available petrol from major oil companies and suppliers.
- Unless otherwise stated, or the distinction is made between leaded and unleaded petrol, major gasoline fuel shall meet the following; Acceptance levels for Octane numbers will be determined at 95% confidence level. Only additives to this motor gasoline fuel solely for the purpose of lead replacement are allowed.
- Lead Replacement Gasoline, LRG, also known as LRP. Only additives from Sodium, Phosphorous, Potassium, or Manganese according to manufacturers recommendations are allowed. Note; Manganese can enhance octane values in any petrol. Under no circumstances will values in excess of 0.005 grams/litre be permitted.
- **Lead in excess of EU directive 98/70EC requirements is illegal.**
- We reserve the right to amend the detail of the above specification to reflect any change occurring in the quality of the fuel on sale to the general public at any time.

Roadside fuel consistency when testing fuel samples

| | | | | | |
|-----------------------|---------------|---------------|---------------|---------------|----------------------------|
| Motor Oct No (max) | 89.0 | 89.0 | 89.0 | 89.0 | ASTM D2700/86 |
| Mon (min) | 85.0 | 86.0 | 86.0 | 86.0 | ASTM D2700/86 |
| Research Oct No (max) | 100.0 | 100.0 | 100.0 | 100.0 | ASTM D2699/86 |
| Ron (min) | 95.0 | 97.0 | 97.0 | 97.0 | ASTM D2699/86 |
| Lead (max) | 0.005 | 0.005 | 0.15 | | ASTM D3341 / IP362 |
| Lead (min) | ASTM D3237 | ASTM D3237 | | 0.005 | ASTM D3237 / D3341 / IP362 |
| Density @ 15° | 0.720 - 0.775 | 0.720 - 0.775 | 0.720 - 0.775 | 0.720 - 0.775 | ASTM D1298/ D4052 |
| Oxygen % max | 2.7% w/w | 2.7% w/w | 2.7% w/w | 2.7% w/w | Elemental |
| Nitrogen % max | 0.1% w/w | 0.1% w/w | 0.1% w/w | 0.1% w/w | ASTM D4629/ IP379 |
| Benzene % max | 1.0% v/v | 1.0% v/v | 1.0% v/v | 1.0% v/v | EN238 |
| Sulphur | 150mg/kg | 150mg/kg | 150mg/kg | 150mg/kg | EN ISO 14596 / ASTM D2622 |
| Olefins* | 18% v/v | 18% v/v | 18% v/v | 18% v/v | ASTM D1319 |
| Aromatics* | 42% v/v | 42% v/v | 42% v/v | 42% v/v | ASTM D1319 |

* Olefins and Aromatics values are expressed as a percentage of total fuel.

30. EXHAUST SYSTEM.

- The exhaust system must conform to the following: The original manufacturer's exhaust front pipe or equivalent pattern part must be retained to the rear of the front wheels. You must then connect via a pipe to a single Fordson Major box Part No. E1ADDN5230A. Note: a cross reference box to the Fordson one may be used. You may use the car's original system of silencers (no cherry bombs etc) and the noise level produced by the car must be to the satisfaction of the Promoter, Steward and/or Scrutineer.
- Vauxhall Nova's may use the original exhaust manifold or the twin outlet type from the 1300 cc Astra.
- The exhaust system must not be run through the inside of the car.
- If your exhaust becomes ineffective in the last 5 laps of a race **you** must pull off, as you will be automatically removed from any results.
- A MINIMUM OF 2" (50MM) AND A MAXIMUM OF 10" (254MM) SECTION OF TAIL PIPE MUST BE FITTED TO THE SILENCER FACING REARWARDS OR DOWN – THIS WILL BE MEASURED FROM THE REAR OF THE BOX (NOT THE PIPE).

31. COOLING SYSTEM.

- Radiators are free, but they must not be moved from their original position.
- Electric cooling fans may be wired to a separate switch.
- Interior heaters may be removed.

32. BATTERIES & THE ELECTRICAL SYSTEM.

- The Battery (only one battery is allowed & it must be similar in size to the original one that was fitted as standard) must be securely fixed & covered with a rot proof material, if it is not of the sealed cell type.
- The Battery must **not** be in a battery box. and it must be fitted behind the driver but forward of the axle centre line.
- The battery must be a minimum of 152mm or 6" away from the fuel tank.
- No seatbelt straps must interfere or come into contact with the battery.
- A battery master switch must be fitted in the rear left-hand window and clearly marked "ON- OFF" or have an electrical danger decal.
- A self-starter motor must be fitted & working at all times.
- Plastic battery boxes are not permitted.

33. INTERIOR MIRROR.

- The Interior mirror must be fitted.
- Maximum mirror size is 152 x 100mm or 6"x4" and if glass, it must be covered in a clear plastic film to stop the glass fragmenting.

34. DOOR MIRRORS.

- A Drivers door mirror must be fitted but its mounting must be of a shear or spring loaded type and it must not protrude beyond the extreme body width of the car.
- Maximum mirror size is 152 x 100mm or 6"x4" and if glass, it must be covered in a clear plastic film to stop the glass fragmenting.
- A Passenger door mirror is recommended, its mounting must be as the Drivers door mirror.

35. STOP LIGHTS.

- Stop lights must be fitted facing rearwards & can either be two separate lamps, a minimum of 762mm or 30" apart or a centrally fitted strip-light (LED type).
- When two lights are fitted, either from the underside of the tailgate or the top of the parcel shelf, they must be no greater than 21 Watts in Power.
- The two lamps must be a minimum of 75mm or 3" & a maximum of 127mm or 5" in size, round or rectangular but they must be a pair.
- Strip-lights must be no wider than 406mm or 16".
- The lights must operate off of a standard brake stop light switch.
- All brake lights must be red.

36. PAINTWORK.

- The external appearance of the car must look bright & professional at all times drivers of scruffy looking cars will be told to improve their appearance & may not be allowed to race.
- A maximum of two cars may be painted in team colours or painted to look similar, unless it is required by the Promoter for a particular team event.
- Sign writing must be professional and be approved by the Promoter.

37. SUN VISOR.

- A Sun visor 165mm or 6" in depth must be fitted with your first and last name written upon it.

38. FIN PLATES.

- Fin plates must be fitted above the roof line but they should not be larger than 305mm or 12" by 559mm or 22" wide.
- Fin plate numbers must be 229mm or 9" high by 38mm or 1½" in width, black numbers on a white background. Please ensure they are correct.

39. DOOR NUMBERS

- The drivers racing number must appear on both sides of the car. The numbers should be 300mm or 12" high x 50mm or 2" wide, on a contrasting background, which must extend a minimum of 50mm or 2" beyond the numbers.

40. SPECIFICATION AND RULE CHANGES.

The Promotion may at any time make amendments to the Specifications for the following reasons:

- In the interests of Safety
- Reduce costs for the driver
- In areas that are detrimental to the future of the formula
- If an unnecessary advantage has been deemed.

Current registered drivers will be notified automatically of any changes.

41. ROOF GRADING

Rookie Rod grades are to be displayed via the car roof fins and not the roof itself.

- The fins must be as follows:-

White Grade – Black numbers on White background

Yellow Grade – Black numbers on Yellow background

Blue Grade – White numbers on Dark Blue background

Red Grade – White numbers on Red background

Points Champion – Black numbers on silver back ground

- The rear of the fin plate must be plain and white in colour.
- The roof of a car may display a championship status providing the driver is the reigning champion e.g. World Champion, Southern Champion. No sign writing is permitted on the roof of the car displaying previous championship history which is no longer current e.g. the 2015 National Champion cannot display the fact of this in 2017.
- If you win a race at a meeting; you will start the remaining races from the rear of your grade.
- Should you win another race at the same meeting – you will be automatically upgraded. Multi-Champions will start next to the National Points Champion.
- Red grade drivers will start in points order with the lowest points scorer in attendance within the red grade at the front of the respective pack.
- Drivers with the incorrectly shown grade, after the points chart has been issued, will have to start at the rear of the grid.

Grid Line up / Roof Order:

National Points Champion

National Points Leader

Supreme

Red

Blue

Yellow

White

Silver Roof

Silver Stripe

- All roof grade champions must start from the rear of the grid. The only exception to this rule is where time trials, or specific grid orders, are implemented. Any of the champions, racing together, should start in order, as listed e.g. National Points Champion at the back of the grid, etc.

42. SCRUTINEERING OF NEW CARS

- All new cars must be Scrutineered prior to its first meeting. Arrangements must be made with Swaffham to bring the car along to the Stadium on the day of an event and then your car will be Scrutineered.

Please Note:

- Drivers and teams are reminded that a secondary means of supporting a vehicle must be used when working underneath a car that has been jacked up (i.e. axle stands).
- It is your responsibility as a driver to ensure the whole of your car is completely past the car beside you before moving across the track. It is **NOT** the responsibility of the driver coming up beside you to brake and let you in, any contact in this situation will be the blame of the car moving across, for example if you are on the straight approaching a corner on the outside and you cannot move across the track without touching another car do not move across, if you move across and there is contact you will be punished not the other driver.
- Any Driver seen blocking cars from overtaking them by moving across the track will have the points removed for that race (Drivers must not block). If a faster car is behind you, you must choose a line and stick to it. This will be watched very closely.

Please note that all of the above rules are subject to change in respect of Health & Safety requirements.